

LINOFOG MIX

JOINT FILLER LINOFOG MIX

Linofog Mix provides the industry with secure and durable joint filler. Its characteristics are an excellent pressure strength and elasticity.

Linofog Mix is polyurethane-based and best applied with a mix cartridge pistol. Linofog Mix works in cold temperature, all the way down to -50°C ; however, it must not come in contact with water, moisture or low temperatures during application. Linofog Mix has a very good chemical resistant, which are listed below.

A high-quality and professional floor laying is not always sufficient to obtain the best possible result. In order to avoid cracks in concrete floors it has become common practice to saw notches in 6 x 6 m or 8 x 8 m squares, depending on pillars etc. After 3-6 months at the earliest, the joints are vacuum-cleaned, primed, filled and then smoothed with a grinding machine.

Linofog Mix is also suitable for repairing cracks and small repairs.

Acid:	10 % sulphuric acid	Animal:	fat
	50 % phosphoric acid		protein
	50 % chromic acid		blood
Alkali:	1 % caustic soda	Vegetable:	fat
	1 % ammonia		protein
			sugar
Salt:	NaCl	Oil:	crude oil
	Na_2CO_3		light oil
	10 % NaHCO_3		lamp oil machine oil (mineral)

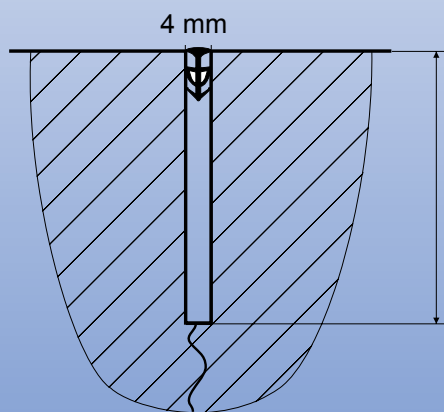

Cutting depth
 $1/4 - 1/3$ of
slab thickness

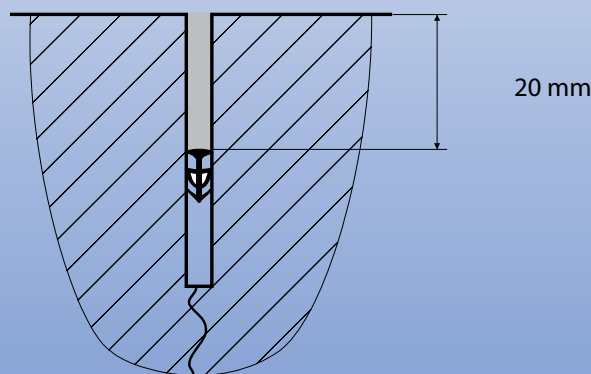

See separate laying instruction.

AB Lindec endeavours to provide correct information about technical properties and handling of its products. However, while ab lindec has no control over the way in which the products are mixed and laid, or the conditions under which they set, ab lindec can in no way be held responsible. ab lindec is only responsible for the quality of the products at the time of delivery.

ab lindec

P.O. Box 5, 421 21 V.Frölunda, Sweden, Tfn +46-31-298810,
Fax +46-31-298876, export@lindec.se, www.concretefloor.com